



**Access  
Institute**

Creating exceptional  
opportunities.

**Accredited SDA Assessor – Update 4 - December 2021**  
**Clarifications re the SDA Design Standard Interpretations**  
**December 2021**

This is the 4th update of Clarifications re the SDA Design Standard Interpretations. This 4th Update also includes the content from Updates 1, 2 and 3. Apart from some grammatical modifications, **changes in this document made since Update 3 are highlighted in purple.**

The SDA Design Standard has now been in use for over 24 months and there are currently more than 80 Accredited SDA Design Standard Assessors registered. Details can be found at <https://sdaassessors.org.au/>

As could be expected with any new program or process, questions arise that may require clarification and/or further information to assist with implementation.

Access Institute Director, (Ms) Joe Manton, the National Disability Insurance Agency (NDIA) personnel from the SDA Supply and Sector Engagement team, Livable Housing Australia (LHA) and Farah Madon, the Lead Technical Writer of the SDA Design Standard, work collaboratively on an ongoing basis, to try and answer questions and clarify matters to provide further clarity to the SDA Design Standard.

To assist in providing information to the marketplace, Access Institute is publishing this fourth E News – **SDA Design Standard – Assessment Update 4**. We have collated a range of information to assist with implementing the **SDA Design Standard** to make it easier for Accredited SDA Assessors, SDA Providers and developers to better understand requirements.

We will aim to do this on a periodic basis to support the use and implementation of the SDA Design Standard.

This Update replaces Update 3 issued in April 2021.

## A1. Accredited SDA Assessor (The Assessor)

### A1.1 Specified Professionals

Currently Architects, Building Surveyors, Access Consultants and Building Surveyors and Occupational Therapists, who meet required prerequisites are nominated as Specified Professionals who are eligible to apply to become Accredited SDA Assessors.

NDIA has confirmed that there are currently no plans to expand the Specified Professionals who are eligible to become Accredited SDA Assessors.

### A1.2 Role of the Accredited SDA Assessor (The Assessor)

The role of an Accredited SDA Design Standard Assessor is to conduct assessments at both Design and Final-as-built against the SDA Design Standard to confirm compliance with the Standard. Assessors have been trained to do this via an NDIA approved training program. Whilst anyone can undertake the training course, only Specified Professionals who meet certain prerequisites can become Accredited SDA Assessors. Further details can be found at [www.accessinstitute.com.au](http://www.accessinstitute.com.au)

If the Accredited SDA Assessor determines that a dwelling meets the compliance requirements at both the Design and Final-as-built stage under the SDA Design Standard, they can issue a Certificate of SDA Category Compliance, SDA Assessment Summary Form and the SDA Assessment Checklist. The Accredited SDA Assessor will register the documents with NDIA.

It is **not the role of The Assessor** to provide advice regarding density requirements, eligibility for, or funding of SDA. Any queries related to these issues should be directed to NDIA.

#### A1.3.1 Design Assessments

At the Design stage It is a requirement that plans include a notation of proposed compliance with the SDA Design Standard or a Finishes Schedule that confirms compliance relating to the following:

- Slip resistance
- Reinforcement of bathroom walls
- Carpet
- Air conditioning
- Internet connection
- Resilient materials for Robust dwellings
- Structural provision for hoist
- Lift
- Emergency power solutions

### A1.3.2 Final as-built assessments

As indicated in the Accredited SDA Assessor Course Learner Handbook, (*which is approved by NDIA*) the role of the Accredited SDA Assessor is to conduct assessments of Design and Final-as-built dwellings against the SDA Design Standard to confirm compliance with the Standard. Compliance is confirmed using detailed assessment forms

Implicit in this is that the Accredited SDA Assessor must undertake the assessment (or multiple assessments if required,) themselves i.e., an Accredited SDA Assessor is required to undertake the review of plans, and an Accredited SDA Assessor is required to go on site and undertake the review of the Final-as-built dwelling. That is one of the reasons why SDA Assessors must be trained to undertake Assessments.

This may involve the Assessor returning on site to inspect the dwelling after the initial onsite assessment, to confirm any amendments required to the Final-as-built dwelling have been completed and the dwelling complies with the SDA Design Standard.

There is no scope to transfer this responsibility on to another third party. It is also stated that letters of compliance must be collected to confirm compliance with specific elements, as detailed in the Assessment Summary Form.

18.7.2 of the Assessor Learner Handbook states that for a final-as-built assessment *an onsite inspection must be completed for each dwelling separately*. This document and its content are endorsed by NDIA to be used to confirm assessment requirements.

This is part of the role of the Assessor and addressed in the training and are requirements for Assessors to issue Certificates of Category Compliance as confirmed by NDIA.

There is a cost associated with having an assessment undertaken. This is the responsibility of the SDA provider (or the Assessor's client). The Assessor is responsible to ensure the assessment process is followed. This includes onsite assessments at final-as-built stage and return visit to inspect any modification made if the initial onsite assessment was deemed non-compliant.

The best way for a client to avoid a requirement for a subsequent assessment at final as built stage is to ensure that the builder builds the dwelling in compliance with the SDA Design Standard in the first instance, as per the assessed design.

## A1.4 Role of Assessor regarding Refurbished dwellings

The SDA Design Standard applies to all 'new builds'. A building is 'existing' stock if it meets the definition as per the SDA Rules 2020. An established building can be refurbished to attract new build prices and must comply with the SDA Design Standard.

Details of minimum spend costs for refurbished dwellings can be found in Appendix F of the NDIS Pricing Arrangements for Specialist Disability Accommodation 2021-22 (previously known as the Price Guide for Specialist Disability Accommodation).

SDA Assessors are not required to advise on any funding related matters and are not required to check if the minimum refurbishment costs are met as that will be checked by the NDIA.

Some common questions have been clarified below

**Question:** If the dwelling is already built (post 1st April 2016 as required for new-build under the SDA Rules) but was not assessed for compliance against the SDA Design Standard, can the dwelling be assessed post construction and be registered for SDA without triggering the minimum spend as noted in Appendix F if no works are required to comply with the SDA Design Standard?

**Answer:** If no works are required and the dwelling is assessed as meeting the SDA Design Standard based on a site inspection, the minimum refurbishment costs would not apply (assuming all other criteria are met). The dwelling still needs to be certified / registered for both design and final as-built stages as these are mandatory.

**Question:** If the dwelling is already built (post 1st April 2016 as required for new-build under the SDA Rules) but was not assessed for compliance against the SDA Design Standard, can the dwelling be assessed post construction and be registered for SDA without triggering the minimum spend as noted in Appendix F if only minor works are required to comply with the SDA Design Standard?

**Answer:** If any works are required to comply with the SDA Design Standard including any minor works, then contact NDIA directly who will consider this on a case-by-case basis.

## A2. Changes to the Registration of Assessment

A2.1 NDIA has advised the following change to registration of completed Assessments undertaken by Accredited SDA Assessors as follows:

Once an Assessment at either Design or Final-as-built stage is completed against the SDA Design Standard, The Assessor must **provide the applicant with 2 documents:**

- Certificate of Category Compliance
- Assessment Summary Form.

**In addition**, the Assessor must register the Assessment by **forwarding the following 3 documents for each individual SDA dwelling to NDIA via email:**

- Certificate of SDA Design Category Compliance
- Assessment Summary Form
- Assessment Checklist

The email address for Registration of the Assessment is [SDAENROLMENT@ndis.gov.au](mailto:SDAENROLMENT@ndis.gov.au)

This certification and registration of documents with the NDIA is required for **BOTH** stages of assessment, design and at final as-built stage. Documents for final as-built stage will not be accepted unless the documents for design have been previously received by the NDIA.

Lodgement of these documents with NDIA **does not constitute enrolment** of a dwelling. Enrolment of a final-as-built dwelling is the responsibility of the SDA Provider. It is not the role of the Assessor to enrol the dwelling.

Term 'registration' in this document means emailing the set of required documents to NDIA by the Accredited SDA Assessor

Term 'enrolment' in this document means enrolling a certified dwelling with NDIA which can only be done by the SDA Provider and not the Accredited SDA Assessor.

**There is no requirement to send any documents to Livable Housing Australia.**

## A2.2 Update to Assessment Checklists

The checklists for all four Design categories have been updated to include a line that requires the assessor to tick a box to state if the Checklist applies to a refurbished dwelling.

Assessors are only required to identify this on the Checklist and are not required to check if the minimum refurbishment costs are met as that will be checked by the NDIA.

A sample with the question in the SDA Assessment Checklists is shown below

The image shows a sample of an SDA Assessment Checklist form. At the top, there is a question: "Does this checklist apply to a refurbished dwelling?" followed by two checkboxes. Below this, the assessor's details are entered, including their name, registration number, and the address of the dwelling. The assessor confirms that the dwelling has been assessed for a certain stage and complies with the requirements listed in NDIS SDA Design Standard Edition 1.1 for Improved Liveability Design Category. The assessor's signature, assessment date, and NDIS SDA Accredited Assessor number are also provided. The form is titled "7" and "NDIS Specialist Disability Accommodation Design Standard Edition 1.1 - Checklist for Improved Liveability Design Category Version 2".

[Figure 1- Image of Checklist showing new question applicable to refurbished dwelling]

SDA Assessors are required to start using the new Checklists as soon as practical or latest by 1st March 2022. Copies of the new checklists will be distributed by LHA.

## A2.3 Details of Provider at Design Stage certification

**NDIS Specialist Disability Accommodation**  
**SDA Assessment Summary Form**

**Details of Provider**

Legal name of Provider: \_\_\_\_\_

Provider Registration Number (PRN): \_\_\_\_\_ ABN of Provider: \_\_\_\_\_

*[Figure 2- Image of Assessment Summary Form showing the questions in regard to SDA Provider details]*

The assessment summary form has a section that requires Legal name of Provider, Provider Registration Number (PRN) and ABN of provider.

From now on at Design stage the Assessment Summary form need not provide the SDA provider details if one is not appointed or known at the Design Certification stage. In this case the details of the entity who has commissioned the assessment should be provided with a note stating who they are.

Examples could be:

- 'XYZ company (owner of dwelling and commissioned this assessment. Registered provider not yet known)'
- 'ABC company (will be an SDA registered provider at time of enrolment)'



### A3. Conflict of Interest – Assessors

At **both Design and Final**-as-built stage, the Accredited SDA Assessor cannot have a connection to the applicant for example by way of employment or some other contractual relationship.

An Accredited SDA Assessor cannot certify, at either Design or Final as-built-stage, any project that has been designed (in their capacity as an Architect or Building Designer) or constructed by themselves (in their capacity, as the Builder) or where they have provided other review services (in their capacity as the BCA Consultant or Building Certifier).

This also extends to another employee or contractor in the company associated with the project. For example, a firm with multiple architects cannot have one architect design and another architect within the same firm certify the project. This is essential to maintain independence and integrity of assessments.

Accredited SDA Assessors certifying dwellings at either Design (Provisional) stage or Final as Built stage must be a third party to the builder, developer and SDA Registered Provider.

There is no conflict of interest where an Access Consultant is engaged to provide advice regarding the SDA requirements of a Design or a Final-as-built dwelling and is also undertaking the role of the Accredited SDA Assessor, as the advisory role is part of the initial SDA Assessment process. Access Consultants are not engaged as a designer of the SDA nor have any statutory capacity e.g., such as a Building Certifier, in relation to NCC certification of the design or construction.

There is no conflict of interest where an Occupational Therapist (*who is also an Accredited SDA Assessor*) is engaged to provide advice to an NDIS participant regarding their specific housing requirements. The NDIS participant is not the applicant for the purposes of the SDA Design Standard Assessment.

**Note:** Working under multiple ABN numbers does not remove the conflict of interest as the Accredited SDA Assessor is the individual person and not an entity or organisation or business. If the Accredited SDA Assessor has received a 'fee' from an organisation in their capacity as an Architect or Builder or BCA Assessor or Principal Certifying Authority, then a contractual relationship has been established creating a conflict of interest. The 'fee' includes any payment for financial advantage received from the organisation or business such as payment of insurances by the organisation or business for the Accredited SDA Assessor.

It is important that there is no conflict of interest including no perceived conflict of interest.

If any Assessor believes they may have a conflict of interest, they should seek independent legal advice regarding this.



#### A4. Certification under Multiple Design Categories

Abbreviations used: Improved Liveability (IL), Fully Accessible (FA) and High Physical Support (HPS) Robust (Ro).

##### **Where same (full) dwelling is to be certified for various design categories.**

A dwelling can be certified under multiple design categories when assessment is via the SDA Design Standard.

For example, a 4-bedroom group home can be designed to meet the requirements of HPS and IL in which case all bedrooms are certified as HPS but can also be used for IL if required.

In this case separate Assessment Summary forms, separate Assessment checklists and separate Certificates of Category Compliance are required for each of the design categories to be certified.

An individual dwelling can be certified for the three design categories of IL, FA and HPS but not Ro. This is because there are elements required in IL, FA and HPS that may not be suitable for Ro. For example, use of AS1428.1 compliant door handles as required in Clause 4.2.6 or shower hose as required in Clause 7.1.7 may not be suitable for use in Ro dwellings.

In cases where Ro features are required in addition to IL, FA or HPS, they can be provided to the extent required by the participant however certification for Ro when the dwelling is certified to IL, FA and HPS cannot be provided. For funding purposes where the design meets IL, FA and HPS, the funding for the high level will apply.

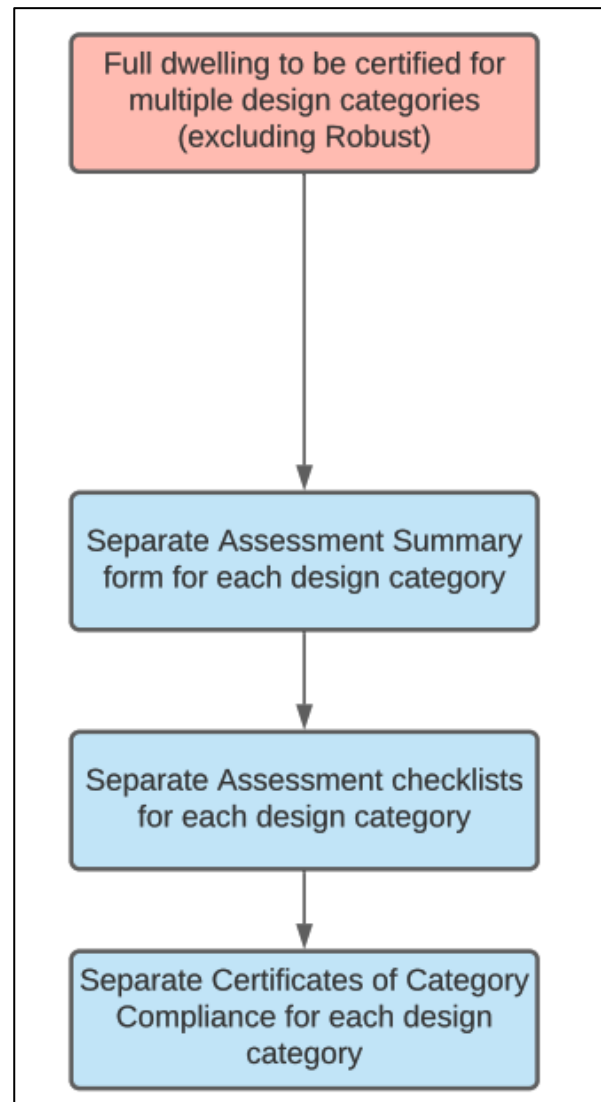

Figure 3- Flowchart showing requirements where same (full) dwelling is certified for various design categories]

It is to be noted that the NDIA is looking into developing Ro requirements further in the future to assist the SDA developers and assessors.

**Where parts of a dwelling are designed for different design categories**

A dwelling can be certified under multiple design categories when assessment is via the SDA Design Standard. For example, a 3-bedroom apartment is designed such that 1 bedroom is designed as per HPS and 2 bedrooms are designed as per IL.

In this case all shared areas must comply with the minimum requirements of all enrolled design categories.

In this case only 1 Assessment summary form, 1 Certificate of compliance (to the highest level) and separate Assessment checklists are required for each of the design categories to be certified. The Assessment summary form has a table which can be filled in to reflect the allocation of the bedrooms to the various design categories.

Please note that an apartment cannot be certified under the Ro design category.

Only 1 Assessment Summary form is required as the table in the Summary form already allows for multiple category bedrooms in the same dwelling

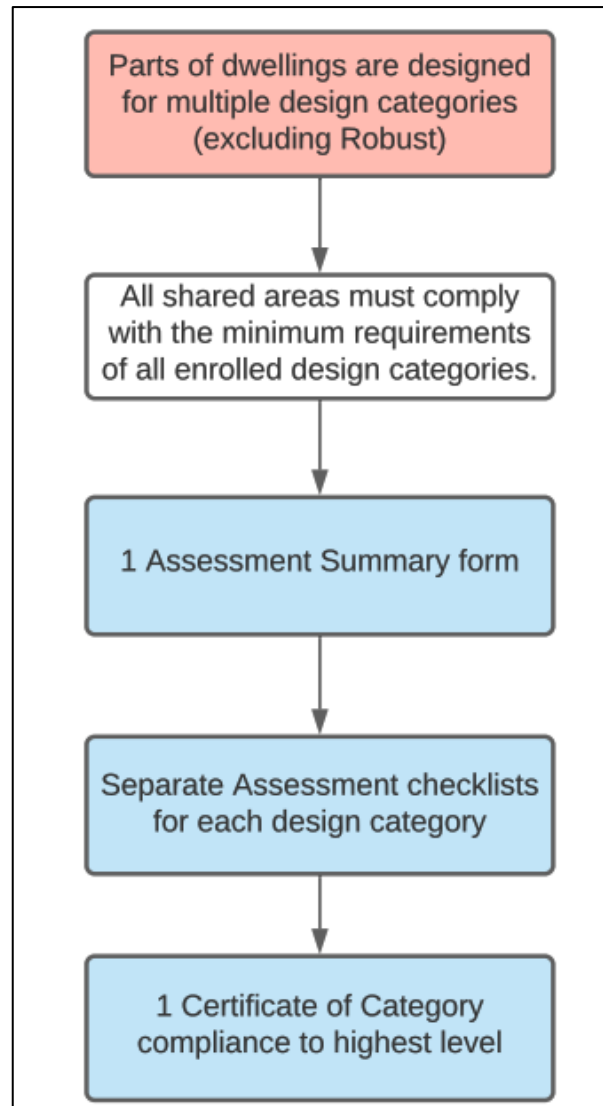

[Figure 4- Flowchart showing requirements where parts of a dwelling are certified for various design categories]

SDA Design Category Summary	
Design Category	Number of Bedrooms
High Physical Support	
Fully Accessible	
Improved Liveability	
Robust	
Non SDA	
<b>TOTAL</b>	*excluding OOA

1

NDIS Specialist Disability Accommodation - Form version SF-01

[Figure 5- Image showing table of bedrooms from Assessment Summary form]

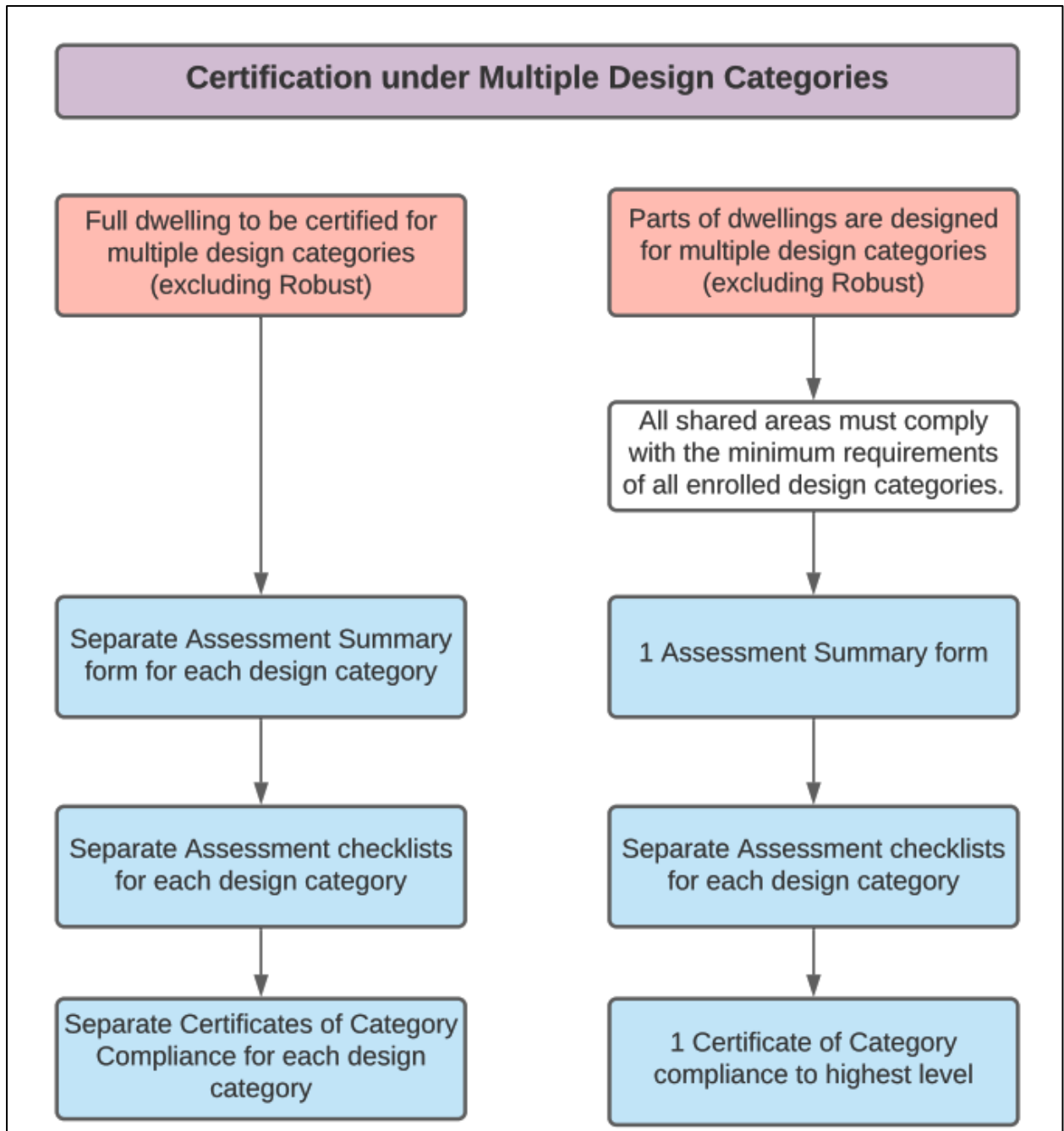

Figure 6- [Image above shows the summary of documents required when certification is provided for multiple design categories (for full dwelling as well as parts of dwellings)]

## A5. Can Design Requirements be varied?

**Minimum design requirements cannot be varied; however**, if additional elements are included over and above the minimum design requirements to enhance accessibility, this can occur as long as this does not impact on the minimum design requirements as detailed in the SDA Design Standard.

Changes to, or reduction or deletion of any minimum specified design requirements will result in non-compliance with the SDA Design Standard.

The **Accredited SDA Assessor has no authority or flexibility in relation to granting exemptions or variations** to the minimum specified design requirements of the SDA Design Standard.

Careful attention should occur at the design stage to ensure that the Final-as-built dwelling will meet the minimum specified design requirements of the SDA Design Standard.

## A6. Changes to designs after assessment

If an applicant changes a design after an assessment is completed and a Certificate of Category Compliance has already been issued by the Assessor, and the Assessor becomes aware of this, they should inform the applicant that another assessment will be required to confirm compliance.

Once the Assessor has undertaken the review of any amendments, if deemed compliant, the Assessor could issue a new Certificate of Category Compliance superseding the original or provide a written amendment to the original Certificate of Category compliance (can be via a letter on the SDA Assessors letterhead) noting that the amendment does not alter the original Certificate of Category Compliance.

It is up to the Assessor to ensure that the Certificate of Category Compliance for the design aligns with the plans provided by the applicant. The Assessor is not responsible for any applicant or SDA provider that uses Certificates of Category Compliance in an inappropriate manner.

It is the SDA provider's responsibility to ensure the Assessor is provided with the latest set of plans even if the plans are updated after Design certification has been achieved.

## A7. Enrolment of SDA with the National Disability Insurance Agency (NDIA)

Only Final-as-built dwellings can be enrolled with NDIA

Only the **SDA Provider can** enrol the SDA. The **Assessor cannot** enrol the SDA.

Further details are provided on the NDIS website

## A8. Design Requirement Interpretations and Clarifications

The following **SDA Design Standard Design Requirement interpretations** are provided for clarity and confirmation.

Considering that the SDA Design Standard is a new document, where a design for a particular dwelling has been certified by the SDA Assessor and emailed to NDIA prior to the release of a particular clarification item, there the SDA Assessor is assured that the NDIA will take no action for their interpretation of the requirement being clarified. It is the intention that all clarifications provided will be incorporated in an updated version of the SDA Design Standard in 2023 as is noted in the Implementation Plan. NDIA holds the right to require an audit by an external party if in doubt of any assessment by an SDA Accredited Assessor.

### Clarification Item 1: Clause 3 Car parking

Provision of car parking is not mandatory for any design category. A car parking space is only required to comply with the requirements of car parking Clause 3, relevant to the design category in the cases below:



- In the case of IL or Ro where an accessible path of travel cannot be provided from the site boundary to the dwelling, and
- In the case where car parking is provided for use by a participant (and not other residents, non-participants of the dwelling or for support staff).

Where the allocation of parking is for staff or non-participants, this needs to be clearly noted on the plans.

Clause 3.5 For all design categories the car parking space (where provided for use by the participant) can also be provided as per AS2890.6.

### Car parking in apartment developments

In apartment developments, it is reasonable not to allocate a particular parking space to a particular SDA apartment. Rather parking spaces can be held by the SDA provider to distribute to SDA participants based on their requirements.

For example, a development has 10 SDA apartments and 5 SDA compliant car parking spaces (3.8M wide or AS2890.6 compliant) and 5 non-compliant car parking spaces. Parking is not mandatory for SDA compliance and therefore the SDA provider can hold these spaces.

When there are 10 SDA participants living in the apartments, 5 of whom drive, the 5 compliant parking spaces should be allocated to them. Where the remaining 5 do not drive, they are allocated standard parking spaces to be used by support staff or visitors.

## Clarification Item 2: Clause 4 Entrance, doorways, and door hardware

Clause 4.2.1, 4.2.2, 4.2.3 The term 'all areas normally used by the participant' means all areas in the participant's home. Clause 4.1.3 requires door circulation spaces to all areas excluding storage and exclusive staff use areas.

For example, it is reasonable in FA and HPS design categories to have an onsite overnight assistance room without the specified door circulation spaces, however the clear door opening requirements still apply so that access is not restricted to an area of a participant's own home. This also applies to an ensuite, or bathroom used exclusively by the support staff where located within the participant's home. No design requirements apply where OOA is a separate apartment in a residential apartment building.

## Clarification Item 3: Clause 6 Windows

Clause 6.1 that requires all windowsills in living areas to have a sill height of not more than 1000mm does not apply to any clerestory windows or high light windows that are provided in addition to the compliant sill height windows in living areas. 

Clause 6.2 relates to location of window controls and Clause 6.3 relates to requirements of power and control cabling to windows of bedrooms and living areas. In relation to bedrooms, it is reasonable to apply these requirements only to participant bedroom/s.

Clause 6.4 related to provision of lockable windows.

This requirement is not for physically preventing the free exit of a participant from premises but for security of the participants should they like to make use of the same. This is similar to the provision of a lockable main entry door to the premises where it is provided for security of the residents rather than a means of containment.

Use of security screens does not negate the requirement for window locks.

## Clarification Item 4: Clause 7 Sanitary facilities

Under Clause 7.2 Wall reinforcements to sanitary compartments; wall reinforcements are required to a minimum height of 2100mm from finished floor level (FFL). It is reasonable to have window openings in the walls of sanitary facilities, however, the Accredited SDA Assessor should exert some judgement on location of windows so that they will not encroach on the future installation of grab-rails in line with AS1428.1. 

In addition to this, Clause 7.2.2 already notes that a 600mm minimum length of wall reinforcement forward of the WC pan is required to be provided without openings, and therefore this area is also to be kept clear of any window openings/ window frames.

Recessed shelving can be provided as long as they are not in the region required to install AS1428.1 compliant grab-rails.



## Clarification Item 5:

### Clause 7.17 and 7.1.8

Figure 10 notes for FA and HPS design category that use of a shower screen is not permitted. Clarification is provided that the use of a shower screen is not permitted **if** it encroaches on any required WC pan, basin, and shower circulation spaces as shown in Figure 8 of the SDA Design Standard.



It is also clarified that SDA Design Standard requires the shower floor grade to comply with AS1428.1. This is limited to the shower area (1100mm x 1160mm) and not the circulation spaces for the shower.

## Clarification Item 6: Clause 8 Kitchen

Clause 8.6, for FA and HPS design categories, the accessible benchtop surface of a minimum 600mm depth shall be provided 'right next to' the cooktop and wall oven on the latch side of the oven door.

'Right next to' means abutting the cooktop and wall oven (i.e., same wall as that of the wall oven and cooktop) as indicated in figure below.

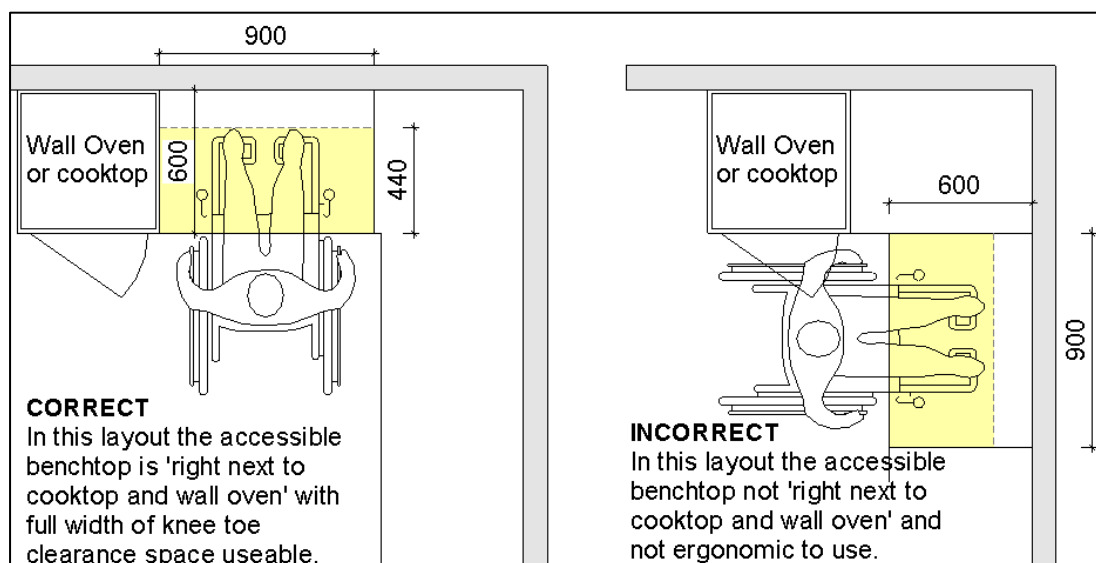

[Figure 7- Figures clarifying the requirements of accessible benchtop locations in kitchens]

The diagrams above show location of the 'accessible benchtop' in relation to the oven or cooktop.

Rationale: Accessible benchtop at 90-degree bends or at corners makes it difficult for a person who uses a wheelchair to move items from within the oven or from the cooktop, then turn wheelchair 90 degrees to place the items on to the accessible benchtop. This location may also cause issues with operation of a side hinged oven door.



Clause 8.6 for FA and HPS design categories, also notes the requirement of a 600mm depth bench top and that 'the accessible benchtop shall provide a minimum space of 900mm(width) x 440mm (depth) clear of any fixtures.

This means that the full top surface of 900mm(width) x 600mm (depth) of the accessible kitchen benchtop is to be clear of ANY fixtures including GPOs (even if the GPOs are bench surface mounted but recessed) or other fixtures such as recessed bins. There is no restriction on using the recessed fixtures on the benchtop as long as the top surface area of the accessible benchtop is kept clear.

The Clause also notes that the accessible benchtop is to have no fixtures other than what is permitted under the knee/toe requirements. This includes all fixtures under the benchtop including any frames or brackets or mechanisms used for benchtop automation.

Note that a height adjustable bench is not required to be automated. Where automation is provided, the SDA Assessor is required to check the capability of benchtop movement from 720mm (clear space under benchtop) to 1020mm (clear space under benchtop) at final as-built inspection.

Where the height adjustment capability is going to be provided by a technician / kitchen installer, written confirmation is to be obtained from the Builder/ kitchen installer that the provision is capable of providing the required clearances.

### Clarification Item 7:

Clause 12.3, power points behind fixed appliances (such as behind fridge, behind a dishwasher, behind a microwave, behind a wall mounted TV) where physical access is limited and where the switch is not required to be switched on/ off for regular day to day use, can be excluded from provision of large / 35mm switches.

The same logic applies to Clause 6.3 where power is required to be provided to windows of bedroom and living areas. A capped GPO to the head of the window is an option and if a power point is provided in lieu of capped GPO to comply with the requirements in this clause then these switches at the head of the windows can be excluded from provision of large / 35mm switches.

### Clarification Item 8: Clause 10 Bedroom

A **built-in robe** (not movable robe) is required to all participant's bedrooms.

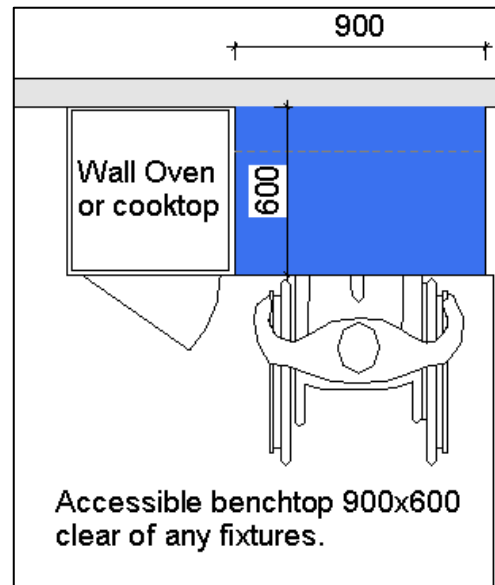

[Figure 8- Figure showing the requirements of accessible benchtop depth in kitchen]



### Clarification Item 9:

For FA and HPS, where there is an ensuite access for the participant from within the participant's bedroom, or access to a balcony or POS (Private open space) from within the participant's bedroom, the door circulation spaces of the ensuite door / door to balcony / POS are required to be clear of the space required for the bed.

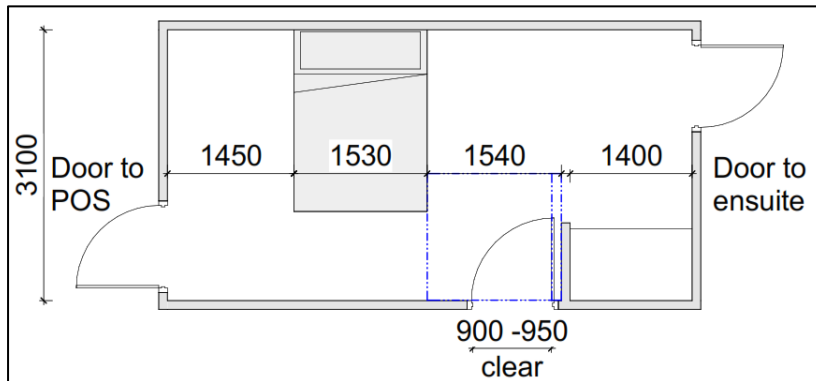

[Figure 9- Figure showing a sample design of bedroom with ensuite and private open space / balcony access]

### Clarification Item 10: Clause 12 Switches and PowerPoints

Light switches shall be positioned in a consistent location between 900mm and 1100mm above FFL (*Typo in SDA Design Standard currently states 900mm – 1000mm*)

### Clarification Item 11: Clause 15 Use of lifts

Stairway Platform lifts are not permitted for access to or within the dwelling. These types of lifts travel on the stairway itself and the platform is folded up against the wall when not in use.

### Clarification Item 12: Clause 16 Common use external areas, private open space and landscaping.

Clause 16.2 requires that an individual letter box (where provided) needs to be on a hard-standing area of 1540mm x 2070mm. This means that the letterbox needs to adjoin a clear floor space of 1540mm x 2070mm for access. A person using a mobility aid must be able to access their mailbox.

### Clarification Item 13: Clause 17 Storage

A dwelling must be provided with a storage cupboard with a minimum 600mm width and adjustable shelf heights. This storage cupboard is to be located in a common area within the dwelling and not in a bedroom.

Full height (minimum 2000mm height) with minimum 600mm clear width (facing user) is required for storage cupboard. Areas under kitchen benchtops and the like are not considered to be compliant with the requirements of this clause.

## Clarification Item 14: Clause 23 Assistive technology

If there is a requirement to initially activate assistive technology using switches, then these switches must be in accessible locations.

There is no requirement for intercom / video communication systems to be hardwired. Reliance can be made on other available technology as long as it is provided on site during final-as-built inspection.



## Clarification Item 15:

When a bedroom is allocated for use by an SDA participant, and that bedroom has an ensuite, it is expected that the ensuite would be designed for use by the participant using that bedroom, based on the sanitary facility requirement of the relevant Design Category.



## Clarification Item 16: Onsite Overnight Assistance

Some frequently asked questions relating to Onsite Overnight Assistance (OOA) assistance are addressed below:

**Question:** I have a 3 Bedroom SDA apartment with only 2 Participants. Can I use the third bedroom for OOA?

**Answer:** This scenario is not permitted for OOA payment in apartments under the The NDIS Pricing Arrangements for Specialist Disability Accommodation (previously the Price Guide for Specialist Disability Accommodation)



**Question:** I have 15 SDA Apartments that require OOA. Can I claim OOA payment for all 15 SDA apartments if I provide one OOA apartment?

**Answer:** OOA is paid per maximum of 10 SDA units. Therefore, if 15 SDA units are to receive the OOA funding, 2 OOA units will be required. If only one OOA is provided, then OOA would be payable to 10 SDA units only. No payment would be available for the additional 5.

**Question:** Can an OOA room be designed as an office without a bed provided?

**Answer:** There are no set requirements for provision of a bed in an OOA room, though it is important to remember that the OOA room will be used by the SIL provider to be on site (24 hours). Therefore, even though not mandated, it is recommended that a space for a bed in the OOA room is provided.

**Question:** Can an OOA room be provided within an FA or HPS dwelling with only a stairway access available to the OOA room?

**Answer:** No. Where OOA is provided within an FA or HPS dwelling there it is required to be on a level accessible to the participant.

**Question:** To claim OOA funding for apartments can a OOA room be provided instead of a full apartment?

**Answer:** No. Where OOA funding is claimed for an apartment, the OOA needs to be a full apartment which would generally consist of a bedroom, living room, kitchen and bathroom. A studio style apartment can be used for OOA.

## **Clarification Item 17: Dwelling type and Building Classification**

### **Dwelling type**

It is the responsibility of the Accredited SDA Assessor to propose the dwelling type and note the same on the SDA Assessment Summary form. The Accredited SDA Assessor shall not rely on or be influenced by the SDA developer in determining the dwelling type.

If all items noted in the SDA Rules 2020 Schedule 1 for type of dwelling are met, then it can be classified as that dwelling type.

The definitions of dwelling type used by the NCC may not necessarily match the definition of dwelling type used by the NDIS. For example, what qualifies as a Group home under the NCC, or Planning Authority can be designed and certified as multiple villas as defined under the Schedule 1 of SDA Rules 2020 as long as all items noted in the SDA Rules 2020 Schedule 1 for type of dwelling are met.

At design stage, an accredited third party SDA assessor must be engaged by the developer to prepare the set of design certification documents, which indicates that upon completion, the dwelling will meet the criteria required for enrolment in accordance with the SDA Design Standard.

The Design Stage Certification documents are submitted to the NDIA by the SDA Assessor. The NDIA will confirm in writing with the SDA Assessor the dwelling type and, only in the case of multi-design the NDIA will also confirm the design categories.

This gives certainty to the SDA market - developers as well as Assessors - that once design stage certification is approved by the NDIA, the dwelling type will not be changed at enrolment.

The NDIA records the information and includes it in data releases to inform the market of pipeline of work under development, noting that commercial in confidence/identifying information will be protected.

**The Design Certificate provided by the SDA Certifier is required to note the dwelling type as one of the following options:**

- (i) Apartment, 1 bedroom, 1 resident
- (ii) Apartment, 2 bedrooms, 1 resident
- (iii) Apartment, 2 bedrooms, 2 residents
- (iv) Apartment, 3 bedrooms, 2 residents

- (v) Villa/duplex/townhouse, 1 resident
- (vi) Villa/duplex/townhouse, 2 residents
- (vii) Villa/duplex/townhouse, 3 residents
- (viii) House, 2 residents
- (ix) House, 3 residents
- (x) Group Home, 4 residents
- (xi) Group Home, 5 residents

### **Building classification**

The SDA Price Guide 2020-2021 states that the Building Classifications in Table 2 are “Typical Building Code” whereas the new SDA Rules 2020 Schedule 1 does not use the word “Typical”. As this point the building classification has to be as per the SDA Rules 2020 or SDA Price Guide 2020-2021 with further details to be provided by NDIA in due course.

Meanwhile SDA Assessors are reminded that the building classification can only be determined by the Building surveyor / Building certifier / PCA or similar state-based authority and not the SDA Assessor.

### **Advice from the Australian Building Codes Board (ABCB)**

NDIA does not provide advice in relation to building classification for a dwelling. Due to concerns expressed by SDA Assessors, NDIA has sought responses to some commonly asked questions from the ABCB which are listed below.

**Question:** Would Class 1b be required instead of Class 1a in a house if occupants were 'unrelated'

**Response:** Occupants of a Class 1a can be unrelated persons (not from the same family). The NCC does not specifically mention or discriminate between the relationship of people living in a Class 1a building.

**Question:** What is the building classification to use for the residents (SDA participants who all have a disability, some physical and some cognitive)?

**Response:** Building Classification is based on occupant profile

- If the occupants are 'People with disability' then the classification is Class 3. Based on level of care it can be Class 3 Residential care.

- If the dwelling is only for 1 person with a disability, then it can be Class 1a i.e., a person with a disability living with their family members.

- In case of residential apartment buildings, the classification can be Class 2 or Class 3. Change to Class 3 not required if building approval was achieved with Class 2 initially.

## Clarification Item 18: Automated doors

1. No door handle requirements apply to fully automated doors. This is consistent with the provision that no latch side spaces are required for automated doors (Clause 4.2.7) as latch side spaces are required to provide access to the door handle.
2. Clause 4.2.7 states that door automation could be provided as a performance solution in lieu of door latch side circulation space.



Clause 4.2.1, 4.2.2 and 4.2.3 note requirements for clear door opening for 1(one) door panel as per Figure 5.

Based on the similar concession applicable in 4.2.7, if full door automation is provided at the outset along with emergency power solutions to cater for a minimum 2-hour outage, then smaller door panels can be used for sliding doors with smaller door panel size as long as the clear opening size is as per Clauses 4.21 / 4.22 /4.23 (based on the design category)

Refer to AS1428.1 for recommended locations for manual door automation controls where provided.

## Clarification Item 19: Door hardware for sliding doors and sliding flyscreens

Standard glazed sliding doors to outdoor areas are permitted to use the standard sliding door handle where the D shape door handle as per AS1428.1 is not possible to be provided to the door.



[Figure 10- Sample door handle for a glazed sliding doorway]

In the case where flyscreen doors are provided to external doorways it is reasonable to have a door handle that is not fully compliant with AS1428.1

In cases where the sliding glazed doors lead to a POS/ balcony size which is small (like a Juliette type balcony), the door handle shape compliance on the outside of the door (facing the POS/balcony) can be excluded on the basis that the door will not be closed / opened from outside and access to the balcony will be limited due to the size of the POS/ balcony.



Regardless of the design, the doorway threshold for FA and HPS dwellings are still required to be flush from the inside of the unit to provide wheelchair access over the sliding door tracks, and clear door opening requirements and door circulation requirements (as applicable) still apply.



## Clarification Item 20: Common use areas in residential apartment buildings

The SDA Design Standard provides commentary on the relationship between NCC and the NDIS Design Standard by stating that, *“Apart from the spatial requirements as noted in this NDIS SDA Design Standard, where there is a conflict between the NCC and the NDIS SDA Design Standard, the NCC takes precedence”*

This means that the access from the site boundary to the entry door of the SDA units have to comply with all the spatial requirements of the SDA Design Standard in addition to the NCC requirements that apply to this area. For example, the minimum clear passageway width of 1200mm for HPS dwellings will be required from the site boundary to the entry doorway of the SDA apartment and from the SDA apartment to the common open space (COS). This is in addition to the NCC requirement of the passageway being 1000mm.



### Common open space

In large residential apartment building developments, there may be a rare situation that a number of common use spaces have been provided in the development. In this case, the SDA Assessor is required to ensure that access to the specific COSs that are related to the SDA apartments is provided with all requirements of the particular design category.

The SDA Design Standard requirements only apply to common use external spaces such as roof top terraces or common open spaces like a garden. The SDA Design Standard does not mandate provision of associated common use rooms to be designed as per the requirements of the SDA Design Standard, such as common use accessible toilets or gymnasiums or swimming pools within developments. For matters not covered by the SDA Design Standard, the Access related requirements for NCC will apply.



For access to common use spaces from the SDA apartments the following clauses apply.

Clause 4.1 that deals with the requirements for entry as well as external doorways

Clause 4.1.6 that deals with requirements of step-free doorway threshold to external doorways leading to common or private open spaces.

Clause 16 that deals with common use external stairways

Clause 16.1 that deals with letterbox requirements for FA and HPS

Clause 16.3 that deals with all ramps and accessways to all external common use and external private use areas



## Common use stairways in residential developments

This Clause only deals with stairways that are used to access a dwelling or to access a COS by the participant. For example, a flight of steps next to the accessible ramp leading from the site boundary to the dwelling or leading to the COS is required to comply with the SDA Design Standard.



A stairway such as the fire stairway / or main common use stairway connecting multiple floor levels in a residential apartment building is not required to comply with the requirements of Clause 16.1.

### Clarification Item 21: Clause 14. Internal stairways in dwelling.

In case of Ro, FA and HPS, the dwelling can provide an internal stairway as long as lift access is also provided to the level serviced by the stairway. These internal stairways within a dwelling are required to comply with Clause 16.1 and the lift is required to comply with the NCC.

### Clarification Item 22: Clause 2.1 Pedestrian entry from the site boundary

For FA and HPS design categories where the dwelling is on larger parcels of land (excluding medium and high-density locations), a concession is possible for the accessible pedestrian entry from the site boundary. This is noted in the rationale section of the SDA Design Standard. This concession can only be provided by the NDIA in writing. To avail of this concession the Accredited SDA Assessor must request the concession from NDIA on the basis of the following threshold questions,

1. Is the parcel of land a 'larger parcel of land'? and,
2. Is the parcel not in a medium or high-density location?

Note that all parcels in metropolitan cities will be excluded from seeking this concession. The decision on the concessions will be made on a case-by-case basis by emailing [SDAHousing@ndis.gov.au](mailto:SDAHousing@ndis.gov.au)

Note: The SDA Design Standard includes matters that are within the property boundary only, as a developer will not have control of what happens outside the property boundary. However, consideration should be provided to achieve step free access from the Council footpath to the main pedestrian entry point for useability of the dwelling. It is anticipated that this requirement will be detailed in the 2023 version of the SDA Design Standard.

### Clarification Item 24: Clause 9 Laundry

Question: Can the requirement for a laundry tub be removed if the laundry is provided in a combined bathroom which has a basin?

Answer: No, provision of a laundry tub is mandatory.

### **Clarification Item 25: Clause 21 Heating and Cooling**

The SDA Design Standard requires zoning of habitable rooms where ducted AC is provided.

It is reasonable that in the case of a 1-bedroom apartment / villa etc that zoning is not provided as it is only for 1 participant, who will determine the best temperature setting for themselves. Zoning is more beneficial where there is more than 1 participant.

In the case of ducted systems, it is also reasonable that each participant may not be able to completely control the heating and cooling temperature in the room (this is because in a zoned ducted reverse cycle system you cannot have one room with heating and another with cooling).

### **Clarification Item 26: Clause 22 Emergency Power Solutions**

Clause 22.1 requires Emergency power solutions to cater for a minimum 2-hour outage in no less than 2 double GPOs in participant bedrooms and any provided automated doors that are used for entry or egress. This is generally achieved by UPS (Uninterrupted Power Supply).

This can also be achieved by generators as long as there is no delay in switching on when there is a power failure, and they are dedicated for use by the participants.

Solar Storage batteries are not suitable and must not be used as emergency power.

In any case, it is highly recommended that the provision of Emergency Power solutions be checked by a suitable professional on an annual basis.

### **Clarification Item 27: Clause 20 Ceiling hoists**

Hoists (the hoist assembly can be provided in the future) are to be capable of being either ceiling mounted, or wall mounted. If it is the intention to make provision for a wall mounted ceiling hoist, this needs to be noted on the plans at Design Certification stage and for final-as-built stage of SDA certification, the wall structure shall be inspected and certified by a qualified structural engineer as being suitable for ceiling hoists with minimum load capacity of 250kg.

### Clarification Item 28: Clause 4.2.10

For the Robust design category, laminated glass or polycarbonate resin thermoplastic material is mandated for all glazed areas, glazed doors and side lights. This is because toughened glass can shatter into pieces whereas laminated glass holds in place when shattered.

NCC/BCA takes precedence over the requirements of the SDA Design Standards.

The NCC requires buildings in bushfire prone areas to comply with AS 3959 for bushfire construction. AS 3959 requires a particular thickness of Grade A safety glass for different Bushfire Attack Levels (BAL). AS 3959 refers to AS 1288 for the type of glass that is considered to be Grade A safety glass which includes “toughened” or “toughened laminated” glass.

Therefore, toughened type laminated glass is suitable for use in bushfire areas where only laminated glass cannot be used due to NCC/BCA. In this case, the Assessor should obtain a letter from the Builder or a BCA consultant that confirms the NCC requirement prior to providing approval for use of toughened type laminated glass requirements.

### Clarification Item 29: Clause 4.2.8

Actual power and control cabling is required in locations nominated in the SDA Design Standard. Provision of just a conduit and draw wire suitable instead of the actual power or data cable is not acceptable.

### A9. Participants are Paramount

All Accredited SDA Assessors have been appointed based on their skills, experience and qualifications. Therefore, it is expected that Assessors will understand that the needs of the participants of NDIS, who will be the residents of SDA are paramount in any SDA design. This should be at the forefront of any discussion and decisions involving assessors, developers and SDA providers regarding suitability of SDA and compliance with the SDA Design Standard.

### A10. The new SDA Rules released

New SDA Rules were released in June 2020. The SDA Rules have changed to allow more options for participants who are eligible for SDA to choose who they would like to live with.

In line with the SDA Rules changes, the [SDA Operational Guideline](#) has also been updated to:

- provide more transparency about how SDA decisions are made and how funding is included in a participant’s plan
- implement changes to the SDA Rules to remove barriers to participant choice in SDA living arrangements
- improve content in a more accessible and easier to find format.

Further details can be found at:

<https://www.ndis.gov.au/providers/housing-and-living-supports-and-services/housing/specialist-disability-accommodation/sda-registration-and-dwelling-enrolment#sda-rules>

#### **A11. Informal discussion forum for Accredited SDA Assessors.**

Below is a link to an informal Facebook discussion forum for Accredited SDA Assessors. Assessor Registration number will be required to confirm accreditation status. All discussions within the forum are to be treated confidentially.

<https://www.facebook.com/groups/271982797103477>

#### **Further Information**

We will aim to provide these updates on a periodic basis however if you require any further information, please contact [SDAhousing@NDIS.gov.au](mailto:SDAhousing@NDIS.gov.au)

#### **Disclaimer:**

This **SDA Design Standard Assessment Update** has been developed in collaboration between Access Institute, NDIA, LHA and the Lead Technical Writer of the SDA Design Standard. No individual party or writers of the Update take responsibility for any errors, omissions or subsequent changes to requirements relating to Specialist Disability Accommodation.

#### **A12. Continuing Professional Development (CPD) Session for Accredited SDA Assessors**

Given the range of clarifications and updates that have been introduced to support Accredited SDA Assessors with the implementation of the SDA Design Standard, a CPD session is planned for all Assessors within the next 3 months. Further details of this will be provided by Access Institute in due course.